

Test Verification of Conformity

On the basis of the referenced test report(s), the sample(s) of the below product has been found to comply with the relevant harmonized standard(s) to the directive(s) listed on this verification at the time the tests were carried out. The manufacturer may indicate compliance to only the said directives by signing a DoC himself and may affix the CE marking to products identical to the tested sample(s) if the product complies with all CE marking directives that has the product in their scope. In addition, the manufacturer shall file and keep the documentation according to the rules of the applicable directive(s) and shall consider changes of the standards as they may occur. Additional requirements, additional directives and local laws may be applicable.

Applicant Name & Address	: Eaglerise Electronics (Foshan) Co., Ltd. No. 4, East Huanzhen Road, Beijiao, Shunde, Foshan, Guangdong, 528000, China
Product(s) Tested	: Electronic controlgear for LED (Electronic LED driver)
Ratings and principal characteristics	: Input: 220-240 VAC; 50/60 Hz; 0,07 A; Class II; IP 20; SELV; ta 50 °C; tc 75 °C; Independent type; 110 °C thermal protection; Inherently short-circuit proof; MM mark; Output: Constant current type for output; Suitable for direct mounting on normally flammable surfaces; Other parameters refer to appendix for model list.
Model(s)	: EIP008C****LS Remark: The 1st to 4th "*" indicate the output current of LED driver; can be replaced by "0200" to "1000" and increasing in multiplies of 50. "0200" means 200 mA; "1000" means 1000 mA.
Brand name	: 
Relevant Standard(s) / Specification(s) / Directives(s)	: EN 55015: 2006+A1: 2007+A2: 2009/ Limits and methods of measurement of radio disturbance characteristics of electrical lighting and similar equipment EN 61000-3-2: 2006+ A1: 2009+ A2: 2009/ Electromagnetic compatibility (EMC) – Part 3-2: Limits – Limits for harmonic current emissions (equipment input current ≤ 16 A per phase) EN 61000-3-3: 2008/ Electromagnetic compatibility (EMC) – Part 3-3: Limits – Limitation of voltage changes, voltage fluctuations and flicker in public low-voltage supply systems, for equipment with rated current ≤ 16 A per phase and not subject to conditional connection EN 61547: 2009/ Equipment for general lighting purposes —EMC immunity requirements EMC Directive 2004/108/EC
Verification Issuing Office Name & Address	: Same as Legal Entity
Verification/Report Number(s)	: GZ12051857-1/ GZ12051857-1

Note 1 : This verification is part of the full test report(s) and should be read in conjunction with it.

This Verification is for the exclusive use of Intertek's Client and is provided pursuant to the agreement between Intertek and its Client. Intertek's responsibility and liability are limited to the terms and conditions of the agreement. Intertek assumes no liability to any party, other than to the Client in accordance with the agreement, for any loss, expense or damage occasioned by the use of this Verification. Only the Client is authorized to copy or distribute this Verification. Any use of the Intertek name or one of its marks for the sale or advertisement of the tested material, product or service must first be approved in writing by Intertek. The observations and test results referenced from this Verification are relevant only to the sample tested. This Verification by itself does not imply that the material, product, or service is or has ever been under an Intertek certification program.

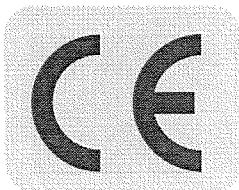

 Signature

Name: Maggie Xie
 Position: Project Engineer
 Date: 30 Aug., 2012



TEST REPORT

Applicant Name & Address : Eaglerise Electronics (Foshan) Co., Ltd.
 No. 4, East Huanzhen Road, Beijiao, Shunde, Foshan, Guangdong, 528000, China

Manufacturing Site : Same as applicant

Sample Description

Product : Electronic controlgear for LED (Electronic LED driver)

Model No. : EIP008C****LS

Remark:
 The 1st to 4th “*” indicate the output current of LED driver; can be replaced by “0200” to “1000” and increasing in multiplies of 50. “0200” means 200 mA; “1000” means 1000 mA.

Electrical Rating : Input: 220-240 VAC; 50/60 Hz; 0,07 A; Class II; IP 20; SELV; ta 50 °C; tc 75 °C; Independent type; 110 °C thermal protection; Inherently short-circuit proof; MM mark; Output: Constant current type for output; Suitable for direct mounting on normally flammable surfaces; Other parameters refer to appendix for model list.

Date Received : 28 May 2012

Date Test Conducted : 15 June 2012 – 19 June 2012

Test standards : EN 55015: 2006+A1: 2007+A2: 2009
 EN 61000-3-2: 2006+ A1:2009+ A2:2009
 EN 61000-3-3: 2008
 EN 61547: 2009

Test Result : Pass

Conclusion : The submitted samples complied with the above EMC standards.

Remark : None.

*****End of Page*****

Prepared and Checked By:

Approved By:

Helen Ma
 Helen Ma
 Project Engineer
 Intertek Guangzhou

Maggie Xie Signature
 Maggie Xie
 Project Engineer
 Intertek Guangzhou
30 Aug., 2012 Date

This report is for the exclusive use of Intertek's Client and is provided pursuant to the agreement between Intertek and its Client. Intertek's responsibility and liability are limited to the terms and conditions of the agreement. Intertek assumes no liability to any party, other than to the Client in accordance with the agreement, for any loss, expense or damage occasioned by the use of this report. Only the Client is authorized to permit copying or distribution of this report and then only in its entirety. Any use of the Intertek name or one of its marks for the sale or advertisement of the tested material, product or service must first be approved in writing by Intertek. The observations and test results in this report are relevant only to the sample tested. This report by itself does not imply that the material, product, or service is or has ever been under an Intertek certification program. The test report only allows to be revised within three years from its original issued date unless further standard or the requirement was noticed.

CONTENT

TEST REPORT..... 1

CONTENT..... 2

1 TEST RESULTS SUMMARY 4

2 EMC RESULTS CONCLUSION 5

3 LABORATORY MEASUREMENTS 7

4 EMI TEST..... 8

4.1 EN 55015 CONTINUOUS CONDUCTED DISTURBANCE VOLTAGE TEST 8

4.1.1 *Used Test Equipment* 8

4.1.2 *Block Diagram of Test Setup*..... 8

4.1.3 *Test Setup and Procedure* 8

4.1.4 *Test Data*..... 9

4.1.5 *Emission Curve* 12

4.1.6 *Measurement Uncertainty*..... 15

4.2 EN 55015 RADIATED ELECTROMAGNETIC DISTURBANCE (9 KHZ-30 MHZ)..... 15

4.2.1 *Used Test Equipment* 15

4.2.2 *Block Diagram of Test Setup*..... 15

4.2.3 *Test Setup and Procedure* 15

4.2.4 *Test Data*..... 16

4.2.5 *Test Curve*..... 17

4.2.6 *Measurement Uncertainty*..... 21

4.3 EN 55015 RADIATED ELECTROMAGNETIC DISTURBANCE (30 MHZ -300 MHZ, CDN METHOD) 22

4.3.1 *Used Test Equipment* 22

4.3.2 *Block Diagram of Test Setup*..... 22

4.3.3 *Test Setup and Procedure* 22

4.3.4 *Test Data*..... 23

4.3.5 *Test Curve*..... 24

4.3.6 *Measurement uncertainty*..... 25

4.4 INSERTION LOSS 25

5 HARMONICS OF CURRENT 26

6 FLICKER..... 26

7 EMS TEST 27

7.1 EN 61000-4-2(PURSUANT TO EN 61547) ELECTROSTATIC DISCHARGE IMMUNITY 27

7.1.1 *Used Test Equipment* 27

7.1.2 *Block Diagram of Test Setup*..... 28

7.1.3 *Test Setup and Procedure* 28

7.1.4 *Test Result*..... 30

7.2 EN 61000-4-6(PURSUANT TO EN 61547) INJECTED CURRENT (0.15 MHZ TO 80 MHZ) 31

7.2.1 *Used Test Equipment* 31

7.2.2 *Block Diagram of Test Setup*..... 31

7.2.3 *Test Setup and Procedure* 31

7.2.4 *Test Result*..... 32

7.3 EN 61000-4-4(PURSUANT TO EN 61547) ELECTRICAL FAST TRANSIENT/BURST 32

7.3.1 *Used Test Equipment* 32

7.3.2 *Block Diagram of Test Setup*..... 32

7.3.3 *Test Setup and Procedure* 33

7.3.4 *Test Result*..... 33

7.4 EN 61000-4-5(PURSUANT TO EN 61547) SURGE IMMUNITY 34

7.4.1 *Used Test Equipment* 34

7.4.2 *Block Diagram of Test Setup*..... 34

7.4.3 *Test Setup and Procedure* 34

7.4.4	Test Result.....	35
7.5	EN 61000-4-11(PURSUANT TO EN 61547) VOLTAGE DIPS AND INTERRUPTIONS	35
7.5.1	Used Test Equipment	35
7.5.2	Block Diagram of Test Setup.....	35
7.5.3	Test Setup and Procedure	36
7.5.4	Test Result.....	36
7.6	EN 61000-4-3(PURSUANT TO EN 61547) RADIATED ELECTROMAGNETIC FIELD IMMUNITY	37
7.6.1	Used Test Equipment	37
7.6.2	Block Diagram of Test Setup.....	37
7.6.3	Test Setup and Procedure	38
7.6.4	Test Result.....	38
7.7	EN 61000-4-8(PURSUANT TO EN 61547) POWER FREQUENCY MAGNETIC FIELD IMMUNITY	39
8	APPENDIX I - PHOTOS OF TEST SETUP	40
9	APPENDIX II- PHOTOS OF EUT.....	44

1

TEST RESULTS SUMMARY

Test Item	Standard	Result
Continuous conducted disturbance voltage	EN 55015: 2006+A1: 2007+A2: 2009	Pass
Radiated electromagnetic disturbance (9 kHz -30 MHz)	EN 55015: 2006+A1: 2007+A2: 2009	Pass
Radiated Electromagnetic Disturbance (30 MHz -300 MHz)	EN 55015: 2006+A1: 2007+A2: 2009	Pass
Insertion loss	EN 55015: 2006+A1: 2007+A2: 2009	N/A
Harmonic of current	EN 61000-3-2: 2006+ A1:2009+ A2:2009	Pass
Flicker	EN 61000-3-3: 2008	Pass
ESD immunity	EN 61547:2009 Reference: EN 61000-4-2: 2009	Pass
Radiated EM filed immunity	EN 61547:2009 Reference: EN 61000-4-3:2006+A1 :2008	Pass
EFT immunity	EN 61547:2009 Reference: EN 61000-4-4:2004	Pass
Surge immunity	EN 61547:2009 Reference: EN 61000-4-5:2006	Pass
Inject current immunity	EN 61547:2009 Reference: EN 61000-4-6:2009	Pass
Power frequency magnetic field immunity	EN 61547:2009 Reference: EN 61000-4-8:1993+A1:2001	N/A
Voltage dips and interruption immunity	EN 61547:2009 Reference: EN 61000-4-11:2004	Pass

Remark: 1. The symbol "N/A" in above table means Not Applicable.

2. When determining the test results, measurement uncertainty of tests has been considered.

2**EMC Results Conclusion**
(with Justification)

RE: EMC Testing Pursuant to EMC Directive 2004/108/EC Performed on the Electronic controlgear for LED (Electronic LED driver), Models: EIP008C****LS.

We tested the Electronic controlgear for LED (Electronic LED driver), Model: EIP008C0200LS, EIP008C0600LS, EIP008C1000LS, to determine if they were in compliance with the relevant EN standards as marked on the Test Results Summary. We found that the units met the requirement of EN 55015, EN 61000-3-2, EN 61000-3-3, EN 61547 (EN 61000-4-2), EN 61547 (EN 61000-4-4), EN 61547 (EN 61000-4-6), EN 61547 (EN 61000-4-5), EN 61547 (EN 61000-4-11), & EN 61547 (EN 61000-4-3) standards when tested as received. The worst case's test data was presented in this test report. Test items Radiated EM filed immunity were subcontracted.

Model List:

Model	Rated input voltage	Frequency	Output voltage range	Max. output voltage
EIP008C0200LS	220-240 VAC	50/60Hz	20V-40VDC	46VDC
EIP008C0250LS	220-240 VAC	50/60Hz	16V-32VDC	37VDC
EIP008C0300LS	220-240 VAC	50/60Hz	13V-26VDC	30VDC
EIP008C0350LS	220-240 VAC	50/60Hz	11.5V-23VDC	28VDC
EIP008C0400LS	220-240 VAC	50/60Hz	10V-20VDC	25VDC
EIP008C0450LS	220-240 VAC	50/60Hz	9V-17.8VDC	24VDC
EIP008C0500LS	220-240 VAC	50/60Hz	8V-16VDC	20VDC
EIP008C0550LS	220-240 VAC	50/60Hz	7.3V-14.6VDC	18VDC
EIP008C0600LS	220-240 VAC	50/60Hz	7V-13.5VDC	16VDC
EIP008C0650LS	220-240 VAC	50/60Hz	6.2V-12.3VDC	15VDC
EIP008C0700LS	220-240 VAC	50/60Hz	6V-11.4VDC	15VDC
EIP008C0750LS	220-240 VAC	50/60Hz	5.3V-10.7VDC	15VDC
EIP008C0800LS	220-240 VAC	50/60Hz	5V-10VDC	15VDC
EIP008C0850LS	220-240 VAC	50/60Hz	4.7V-9.4VDC	14VDC
EIP008C0900LS	220-240 VAC	50/60Hz	4.4V-8.9VDC	14VDC
EIP008C0950LS	220-240 VAC	50/60Hz	4.2V-8.4VDC	13VDC
EIP008C1000LS	220-240 VAC	50/60Hz	4V-8VDC	11VDC

All models had the same mechanical structure, output load, PCB layout; the only difference is the parameters for the components used in secondary circuit. Model EIP008C0200LS, EIP008C0600LS, EIP008C1000LS were selected to do the full tests based on above statement.

The production units are required to conform to the initial sample as received when the units are placed on the market.

3

LABORATORY MEASUREMENTS**Configuration Information**

Equipment Under Test (EUT):	Electronic controlgear for LED (Electronic LED driver)
Model:	EIP008C0200LS, EIP008C0600LS, EIP008C1000LS
Serial No.	Not Labeled
Support Equipment:	N/A
Rated Voltage:	220-240V/50/60Hz
Condition of Environment:	Temperature : 15~25°C Relative Humidity: 35~60% Atmosphere Pressure 86~106kPa

Notes:

1. The EMI measurements had been made in the operating mode produced the largest emission in the frequency band being investigated consistent with normal applications.

An attempt had been made to maximize the emission by varying the configuration of the EUT.

2. The EMS measurements had been made in the frequency bands being investigated, with the EUT in the most susceptible operating mode consistent with normal applications. The configuration of the test sample had been varied to achieve maximum susceptibility.

4 EMI TEST

4.1 EN 55015 Continuous Conducted Disturbance Voltage Test

Test Result: Pass

4.1.1 Used Test Equipment

Equipment No.	Equipment	Model	Manufacturer
EM080-05	EMI receiver	ESCI	R&S
EM006-05	LISN	ENV216	R&S
EM004-04	EMC shield Room	8m×3m×3m	Zhongyu

4.1.2 Block Diagram of Test Setup

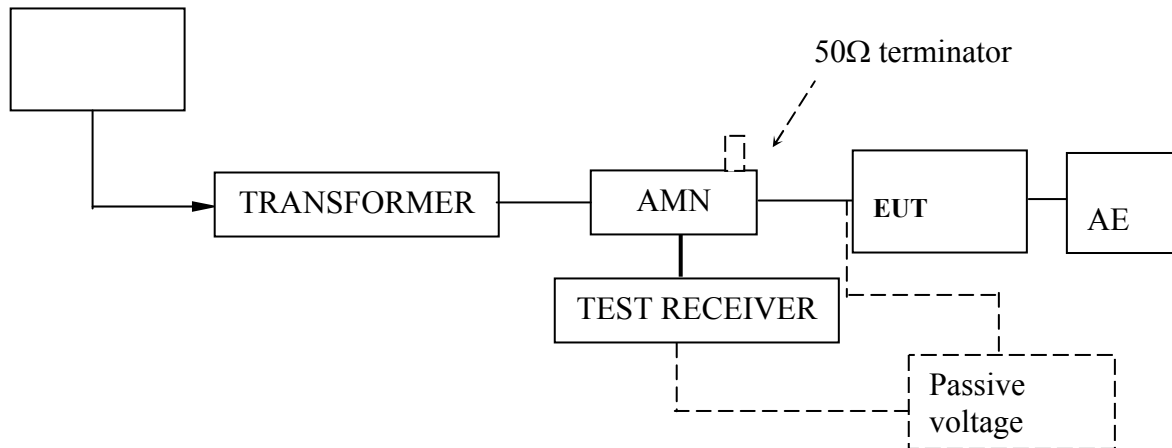

4.1.3 Test Setup and Procedure

The EUT was set to achieve the maximum emission level. The mains terminal disturbance voltage was measured with the EUT in a shielded room. The EUT was connected to AC power source through an Artificial Mains Network which provide a 50Ω linear impedance. Artificial hand is used if appropriate (for handheld apparatus). The load/control terminal disturbance voltage was measured with passive voltage probe if appropriate.

The EUT was placed on a 0.4m high non-metallic table above a metallic plane, and 0.4m from wall of shielded room which is considered as Ground Reference Plane (GRP) (For floor standing EUT, was placed on a 0.1m high non-metallic supported on GRP) The EUT keeps a distance of at least 0.8m from any other of the metallic surface. The Artificial Mains Network is situated at a distance of 0.8m from the EUT.

During the test, mains lead of EUT excess 0.8m was folded back and forth parallel to the lead so as to form a horizontal bundle with a length between 0.3m and 0.4m.

The bandwidth of test receiver was set at 200Hz in the frequency range from 9kHz to 150kHz, and 9kHz in the frequency range from 150kHz to 30MHz.

4.1.4 Test Data

At main terminal: Pass

EIP008C0200LS

Tested Wire: Live

Operation Mode: on mode, full load

EDIT PEAK LIST (Final Measurement Results)				
Trace1:	CE1511QP			
Trace2:	CE1511AV			
Trace3:	---			
TRACE	FREQUENCY	LEVEL dB μ V		DELTA LIMIT dB
1 Quasi Peak	57.24 kHz	65.40	L1	-23.36
1 Quasi Peak	170 kHz	55.66	L1	-9.29
1 Quasi Peak	190 kHz	46.93	L1	-17.10
2 Average	230 kHz	35.69	L1	-16.75
1 Quasi Peak	398 kHz	44.28	L1	-13.60
2 Average	398 kHz	35.73	L1	-12.15
2 Average	622 kHz	34.27	L1	-11.72
1 Quasi Peak	626 kHz	40.70	L1	-15.29
2 Average	906 kHz	33.23	L1	-12.76
1 Quasi Peak	1.302 MHz	44.93	L1	-11.06
1 Quasi Peak	1.642 MHz	43.79	L1	-12.20
2 Average	1.646 MHz	29.07	L1	-16.92
1 Quasi Peak	2.434 MHz	38.73	L1	-17.26

Tested Wire: Neutral

Operation Mode: on mode, full load

EDIT PEAK LIST (Final Measurement Results)				
Trace1:	CE1511QP			
Trace2:	CE1511AV			
Trace3:	---			
TRACE	FREQUENCY	LEVEL dB μ V		DELTA LIMIT dB
1 Quasi Peak	166 kHz	55.02	L1	-10.13
2 Average	166 kHz	46.11	L1	-9.04
2 Average	282 kHz	39.84	L1	-10.91
1 Quasi Peak	390 kHz	46.49	L1	-11.56
2 Average	390 kHz	38.99	L1	-9.06
1 Quasi Peak	618 kHz	46.35	L1	-9.64
2 Average	618 kHz	35.86	L1	-10.13
2 Average	1.01 MHz	36.31	L1	-9.68
1 Quasi Peak	1.286 MHz	47.45	L1	-8.54
1 Quasi Peak	1.622 MHz	46.00	L1	-10.00

At main terminal: Pass

EIP008C0600LS

Tested Wire: Live

Operation Mode: on mode, full load

EDIT PEAK LIST (Final Measurement Results)				
Trace1:	CE1511QP			
Trace2:	CE1511AV			
Trace3:	---			
TRACE	FREQUENCY	LEVEL dBµV		DELTA LIMIT dB
2 Average	178 kHz	33.73	L1	-20.84
1 Quasi Peak	618 kHz	36.42	L1	-19.57
1 Quasi Peak	1.298 MHz	37.63	L1	-18.36
2 Average	1.534 MHz	29.76	L1	-16.24
1 Quasi Peak	1.59 MHz	37.92	L1	-18.07

Tested Wire: Neutral

Operation Mode: on mode, full load

EDIT PEAK LIST (Final Measurement Results)				
Trace1:	CE1511QP			
Trace2:	CE1511AV			
Trace3:	---			
TRACE	FREQUENCY	LEVEL dBµV		DELTA LIMIT dB
2 Average	182 kHz	34.79	L1	-19.60
1 Quasi Peak	374 kHz	41.84	L1	-16.57
1 Quasi Peak	610 kHz	40.31	L1	-15.68
2 Average	1.042 MHz	32.42	L1	-13.58
1 Quasi Peak	1.274 MHz	41.92	L1	-14.07
2 Average	1.506 MHz	32.21	L1	-13.78
1 Quasi Peak	1.582 MHz	39.77	L1	-16.22

At main terminal: Pass

EIP008C1000LS

Tested Wire: Live

Operation Mode: on mode, full load

EDIT PEAK LIST (Final Measurement Results)				
Trace1:	CE1511QP			
Trace2:	CE1511AV			
Trace3:	---			
TRACE	FREQUENCY	LEVEL dB μ V		DELTA LIMIT dB
2 Average	178 kHz	33.52	L1	-21.05
1 Quasi Peak	606 kHz	41.67	L1	-14.32
1 Quasi Peak	1.262 MHz	42.64	L1	-13.35
1 Quasi Peak	2.042 MHz	41.11	L1	-14.88

Tested Wire: Neutral

Operation Mode: on mode, full load

EDIT PEAK LIST (Final Measurement Results)				
Trace1:	CE1511QP			
Trace2:	CE1511AV			
Trace3:	---			
TRACE	FREQUENCY	LEVEL dB μ V		DELTA LIMIT dB
2 Average	182 kHz	34.15	L1	-20.24
1 Quasi Peak	250 kHz	40.60	L1	-21.15
1 Quasi Peak	518 kHz	39.72	L1	-16.27
1 Quasi Peak	618 kHz	38.48	L1	-17.51
1 Quasi Peak	1.286 MHz	42.19	L1	-13.80
1 Quasi Peak	2.014 MHz	39.21	L1	-16.79

At load/control terminal: Not Applicable

Frequency [MHz]	Quasi-Peak		Average	
	Disturbance level [dB(μ V)]	Permitted limit [dB(μ V)]	Disturbance level [dB(μ V)]	Permitted limit [dB(μ V)]
--	--	--	--	--
--	--	--	--	--
--	--	--	--	--
--	--	--	--	--
--	--	--	--	--

4.1.5 Emission Curve
At mains terminal:
EIP008C0200LS
Tested Wire: Live

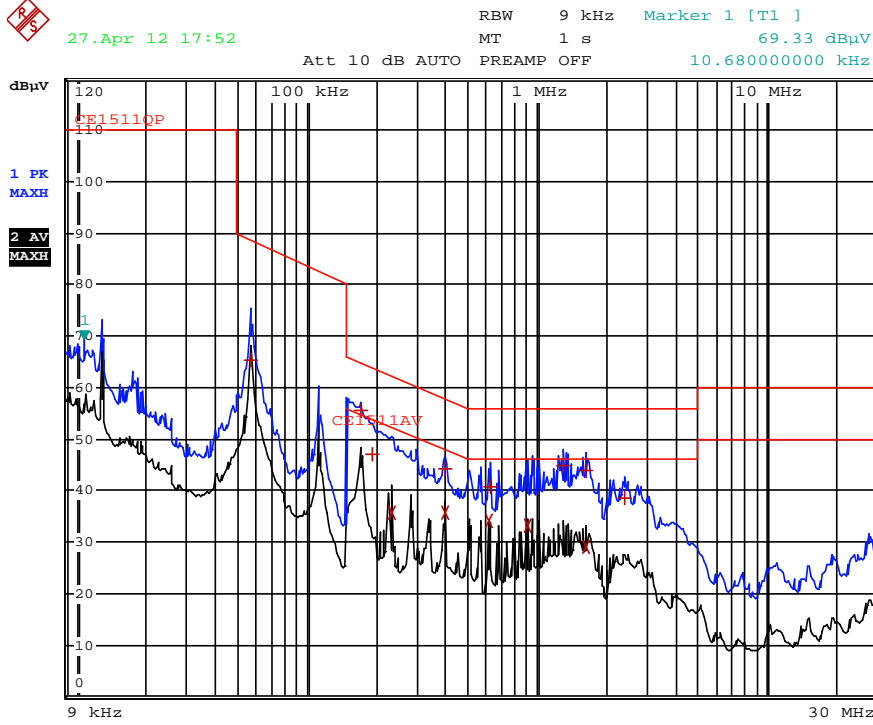

Tested Wire: Neutral

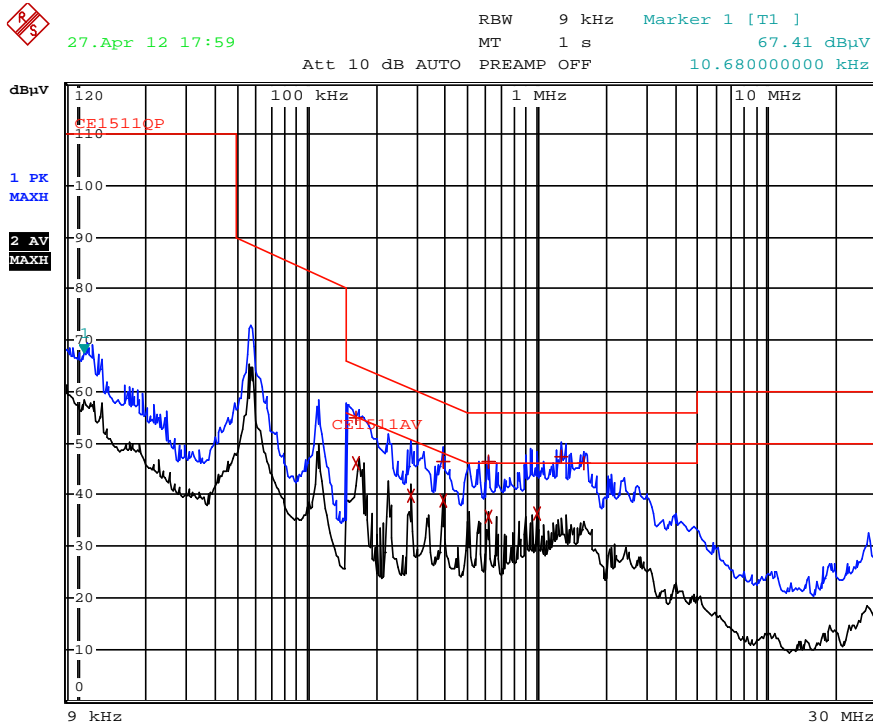



**At mains terminal:
EIP008C0600LS
Tested Wire: Live**

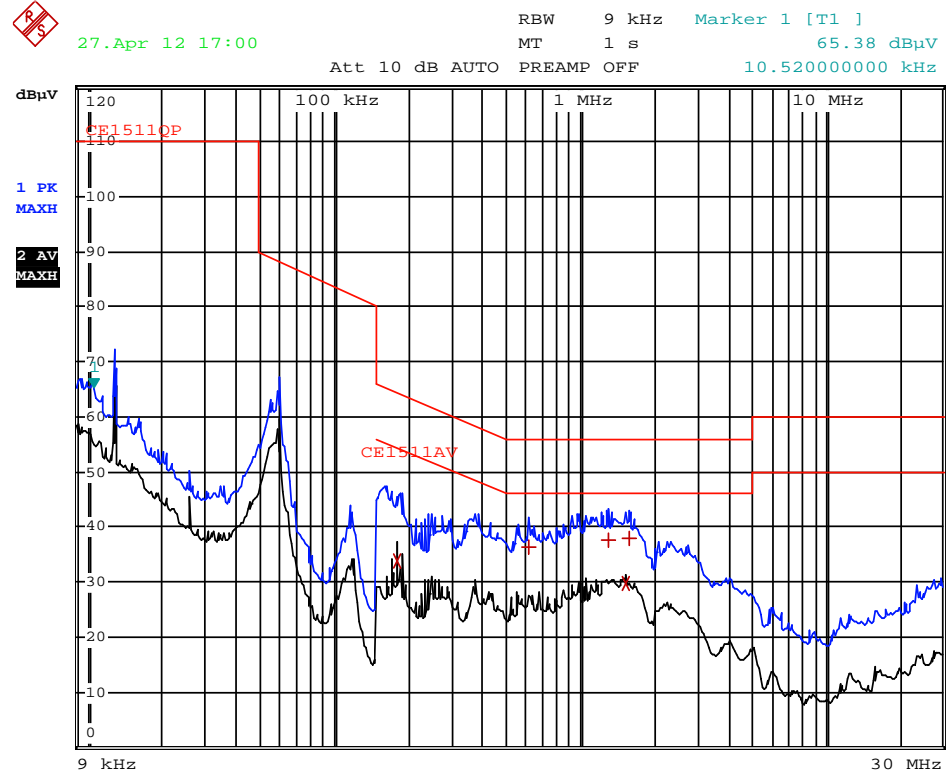

Tested Wire: Neutral

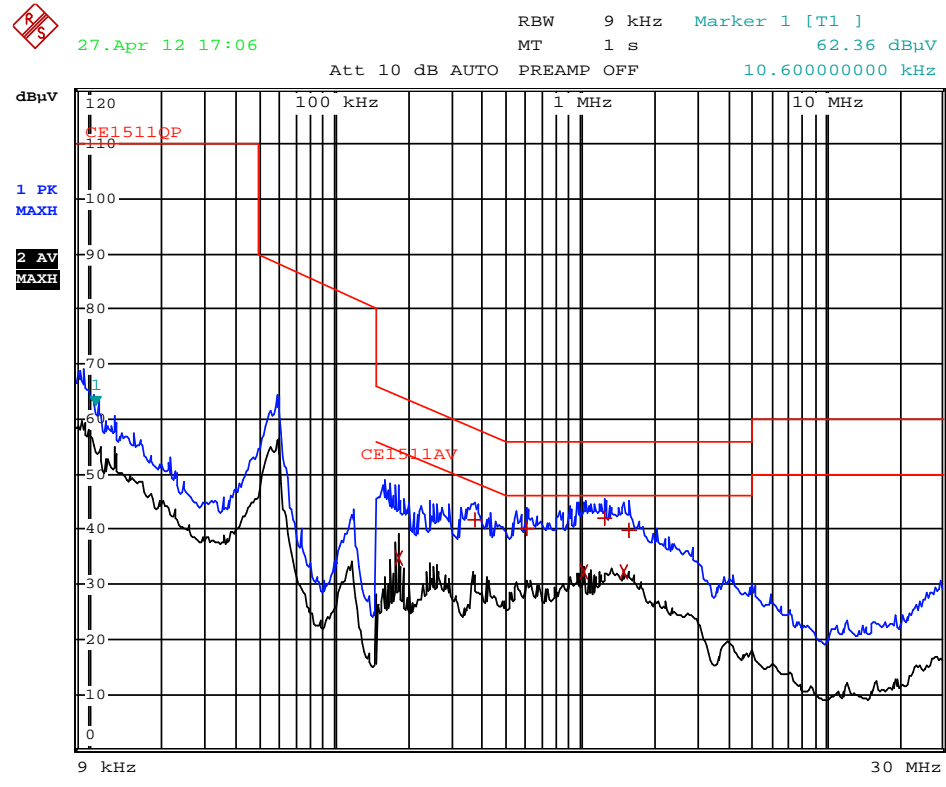

**At mains terminal:
EIP008C1000LS
Tested Wire: Live**

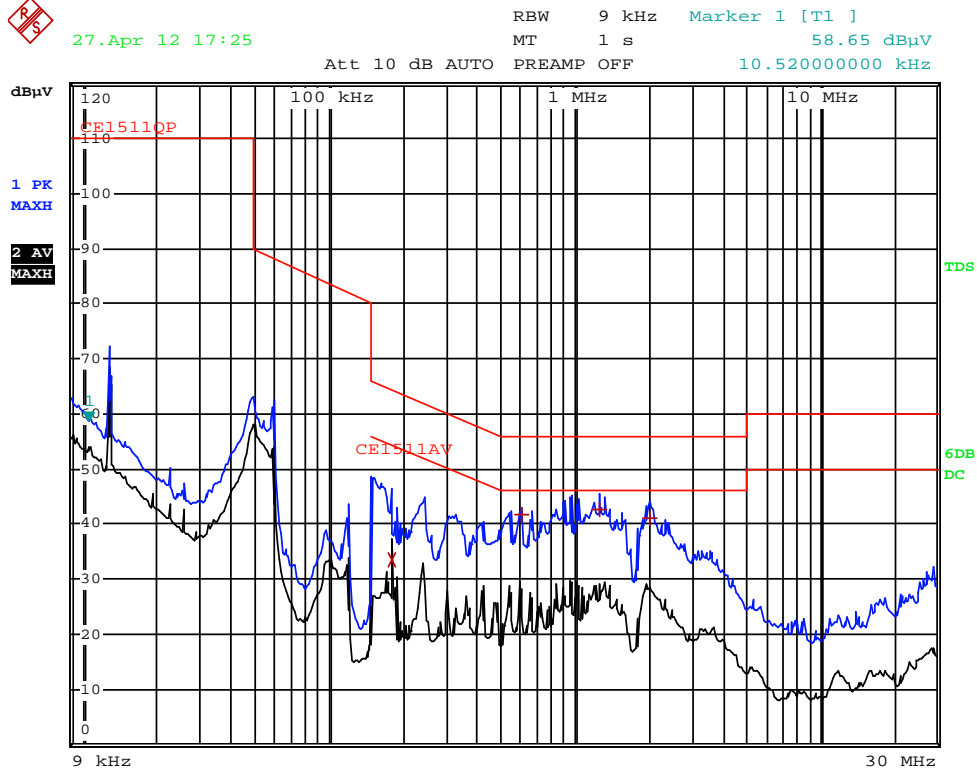

Tested Wire: Neutral

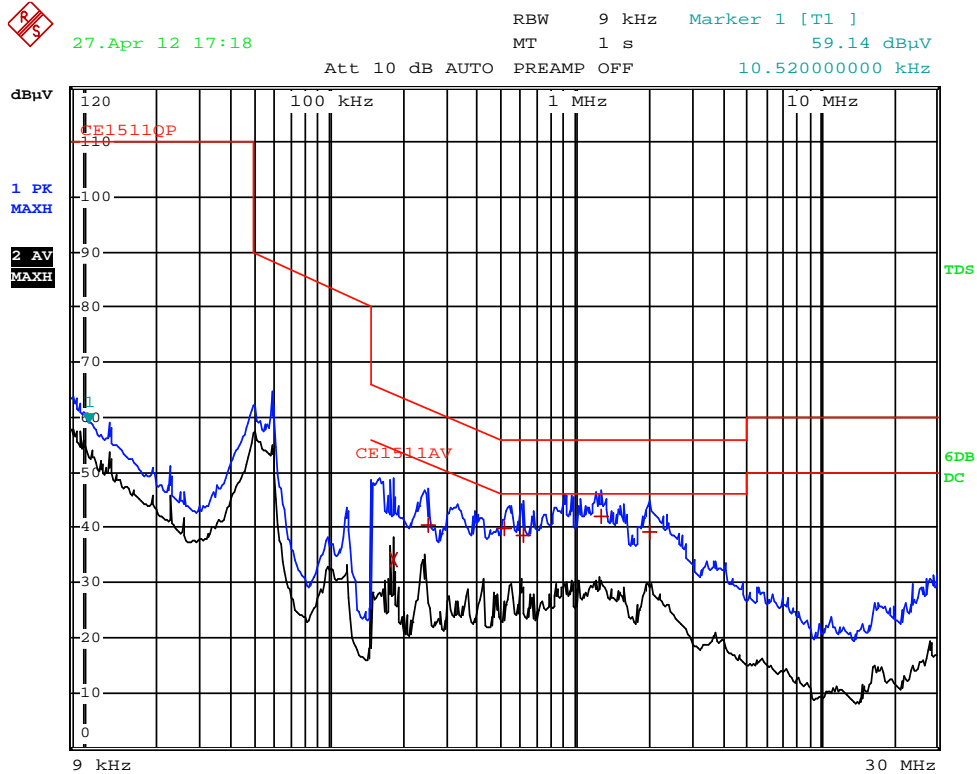

At load/control terminal:
Not Applicable.

4.1.6 Measurement Uncertainty

The measurement uncertainty describes the overall uncertainty of the given measured value during the operation of the EUT.

Measurement uncertainty is calculated in accordance with CISPR 16-4-2: 2003.

Measurement uncertainty of mains terminal disturbance voltage in CISPR band A: 1.6 dB.

Measurement uncertainty of mains terminal disturbance voltage in CISPR band B: 2.3 dB.

The measurement uncertainty is given with a confidence of 95%, k=2.

4.2 EN 55015 Radiated Electromagnetic Disturbance (9 kHz-30 MHz)

Test Result: Pass

4.2.1 Used Test Equipment

Equipment No.	Equipment	Model	Manufacturer
EM080-04	EMI receiver	ESCS30	R&S
EM061-04	Triple Loop Antenna	HXYZ9170	SCHWARZBECK
EM004-03	EMC shield Room	8m×4m×3m	Zhongyu

4.2.2 Block Diagram of Test Setup

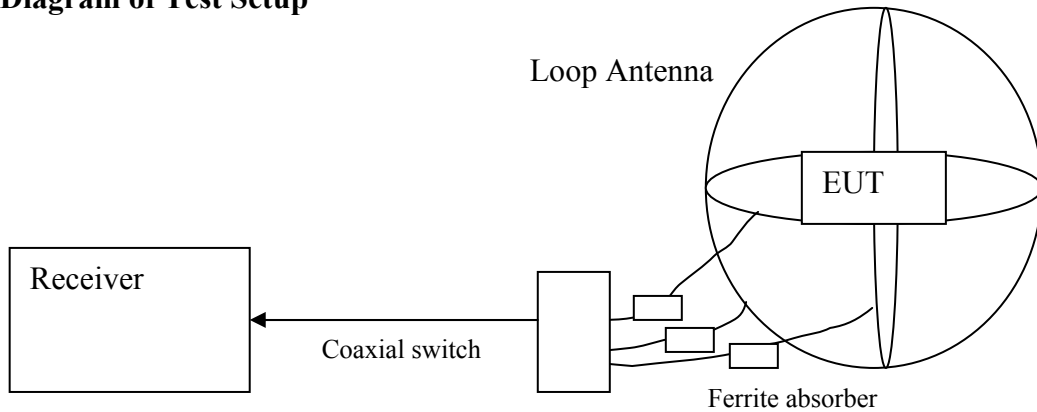

4.2.3 Test Setup and Procedure

The EUT is placed in the centre of the loop antenna system(LAS). The current induced by the magnetic field from the EUT into each of the three large loop antennas of the LAS is measured by connecting the current probe of the large loop antenna to a measuring receiver. During the measurements the EUT remains in a fixed position.

The currents in the three large loop antenna, origination from the three mutually orthogonal magnetic field components, are measured in sequence. Each current level measured shall comply with the emission limit, expressed in dBµA, as specified in table of EN 55015.

The distance between the outer perimeter of the LAS and nearby objects, such as floor and walls, shall be at least 0.5m.

To avoid unwanted capacitive coupling between the EUT and the LAS, the maximum dimensions of the EUT shall allow a distance of at least 0.2m between the EUT and the standardized 2m large loop antenna of the LAS.

The position of the mains lead shall be optimized for maximum current induction. In general, this position will not be critical when the EUT complies with the conducted emission limit.

4.2.4 Test Data

For models: EIP008C0200LS, EIP008C0600LS, EIP008C1000LS

Frequency [MHz]	X axis [dB(μA)]	Y axis [dB(μA)]	Z axis [dB(μA)]	Limit [dB(μA)]
0.009	<78	<78	<78	88.0
0.050	<78	<78	<78	88.0
0.100	<64	<64	<64	74.0
0.160	<47	<47	<47	57.2
0.240	<40	<40	<40	52.4
0.550	<30	<30	<30	42.5
1.000	<25	<25	<25	35.4
1.400	<20	<20	<20	31.4
2.000	<17	<17	<17	27.1
3.500	<12	<12	<12	22.0
6.000	<12	<12	<12	22.0
10.000	<12	<12	<12	22.0
22.000	<12	<12	<12	22.0
30.000	<12	<12	<12	22.0

4.2.5 Test Curve

EIP008C0200LS

X axis

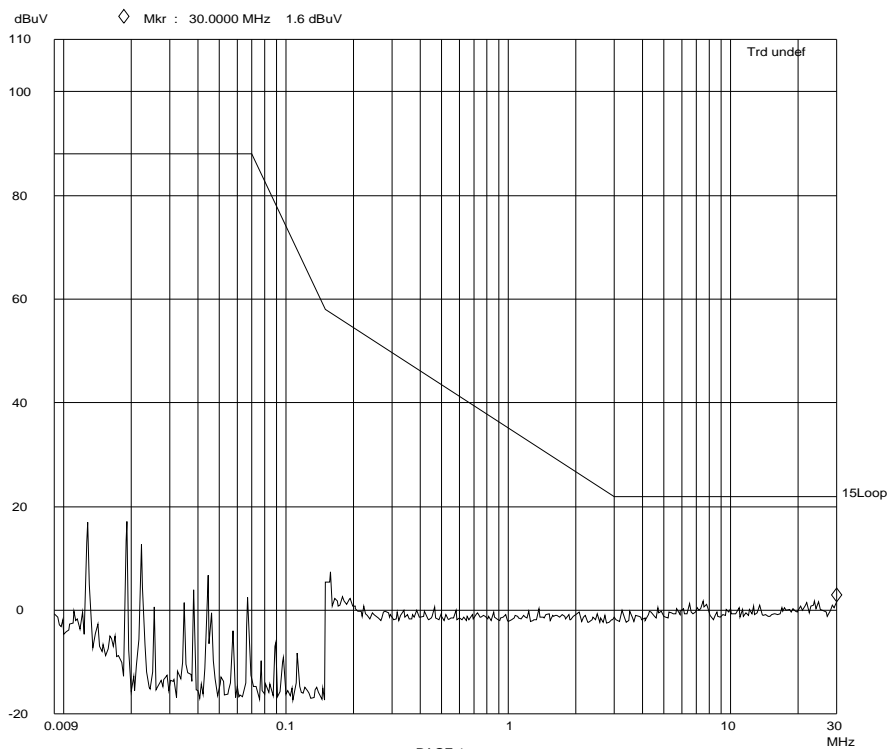

Y axis

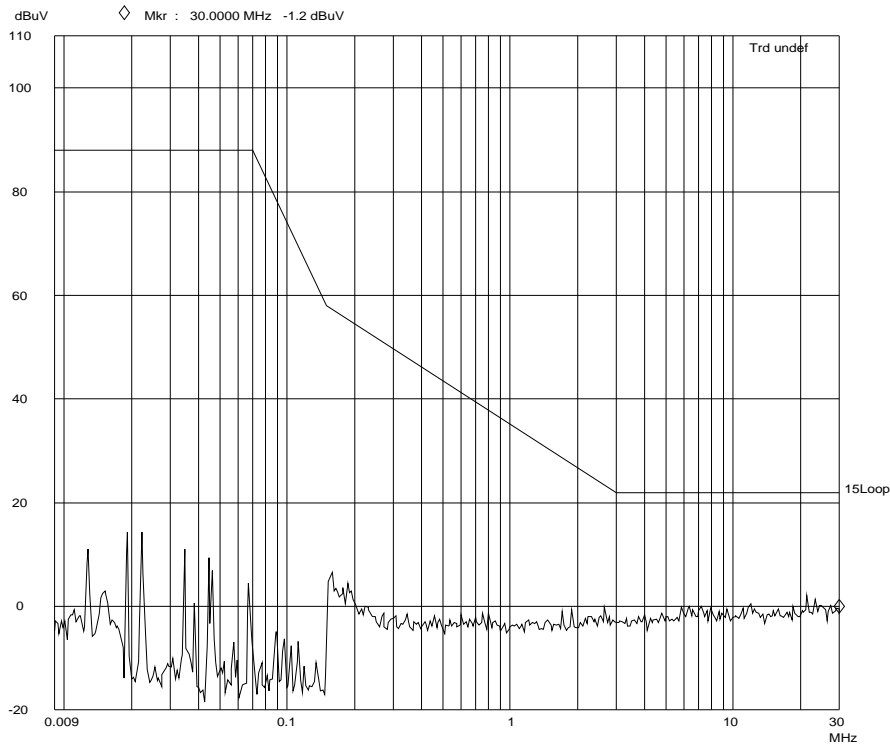

Z axis

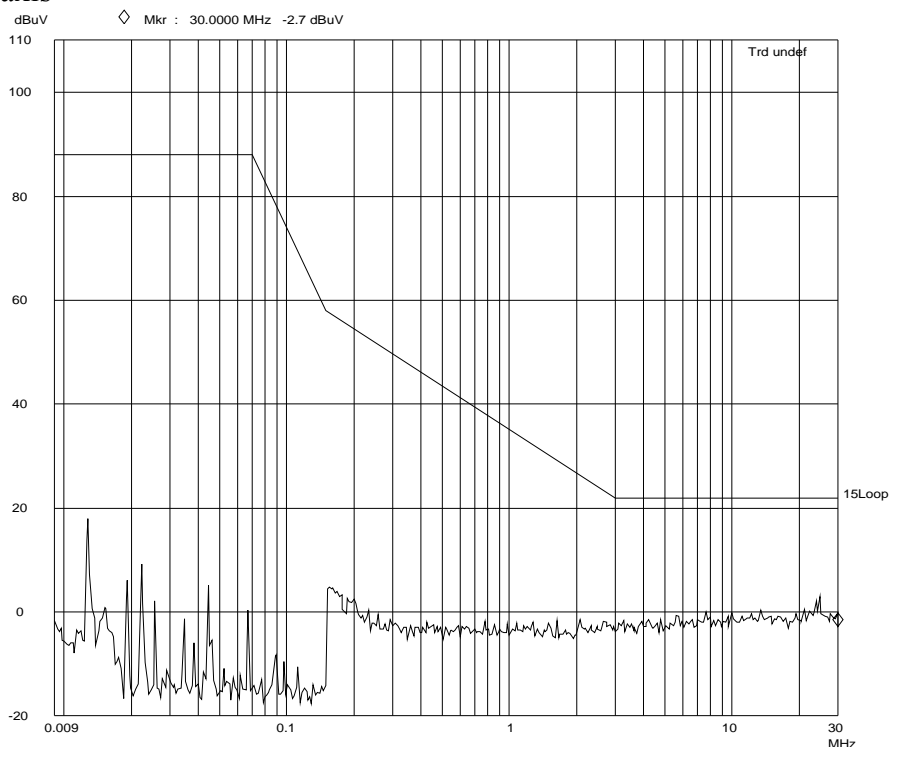

EIP008C0600LS

X axis

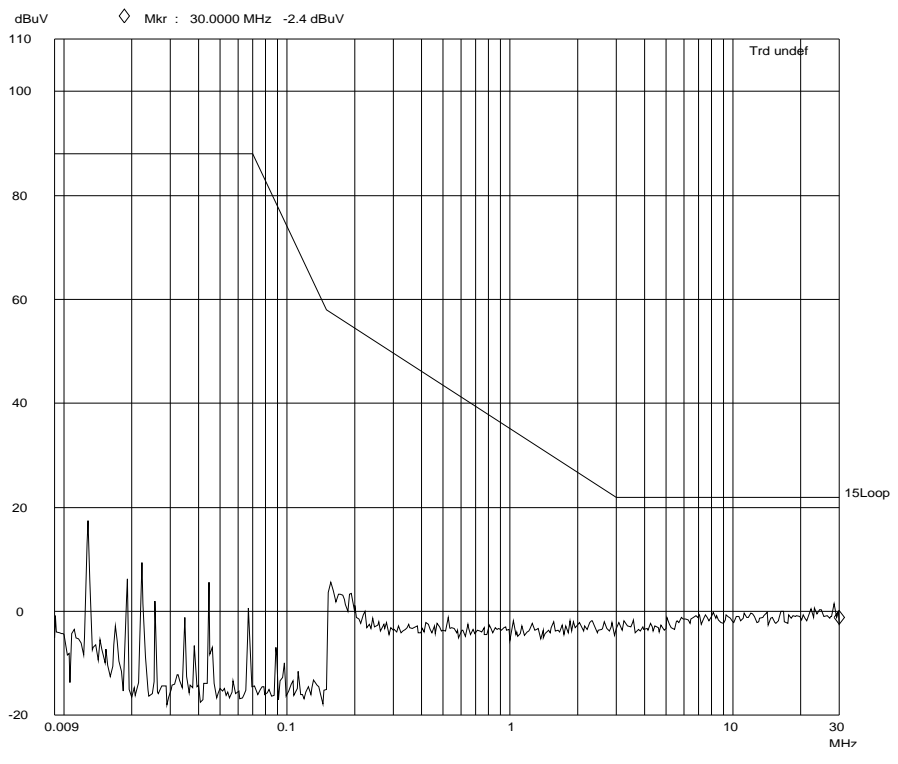

Y axis

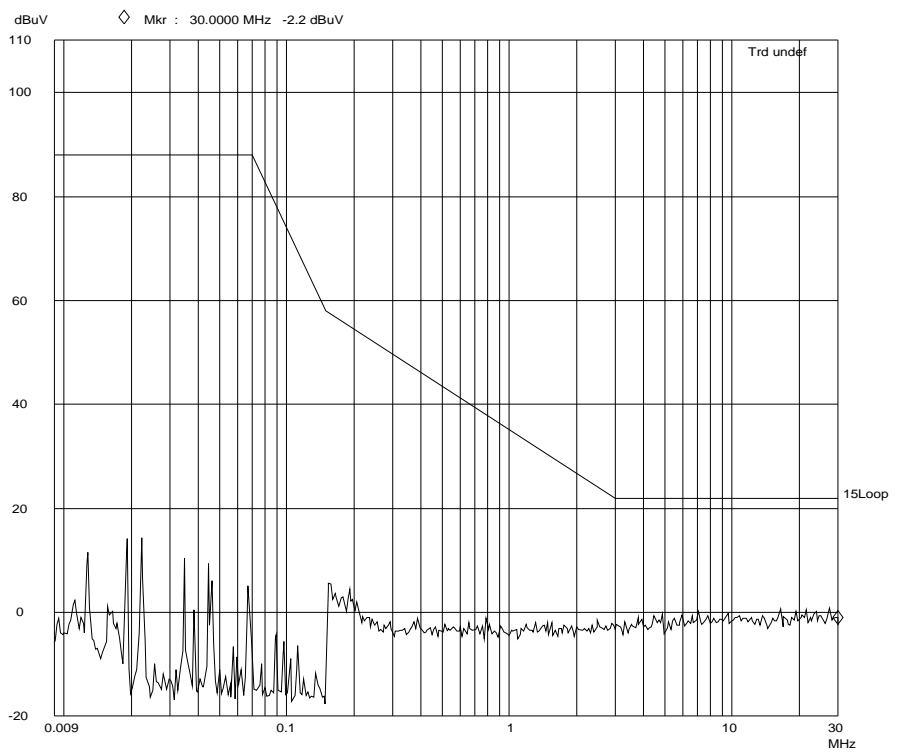

Z axis

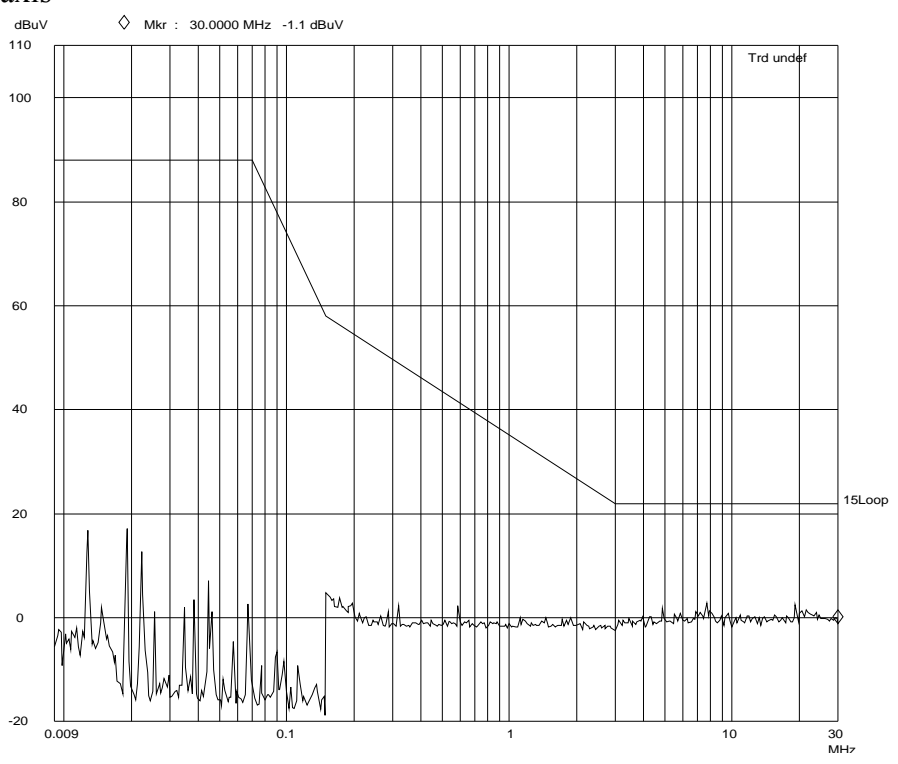



EIP008C1000LS

X axis

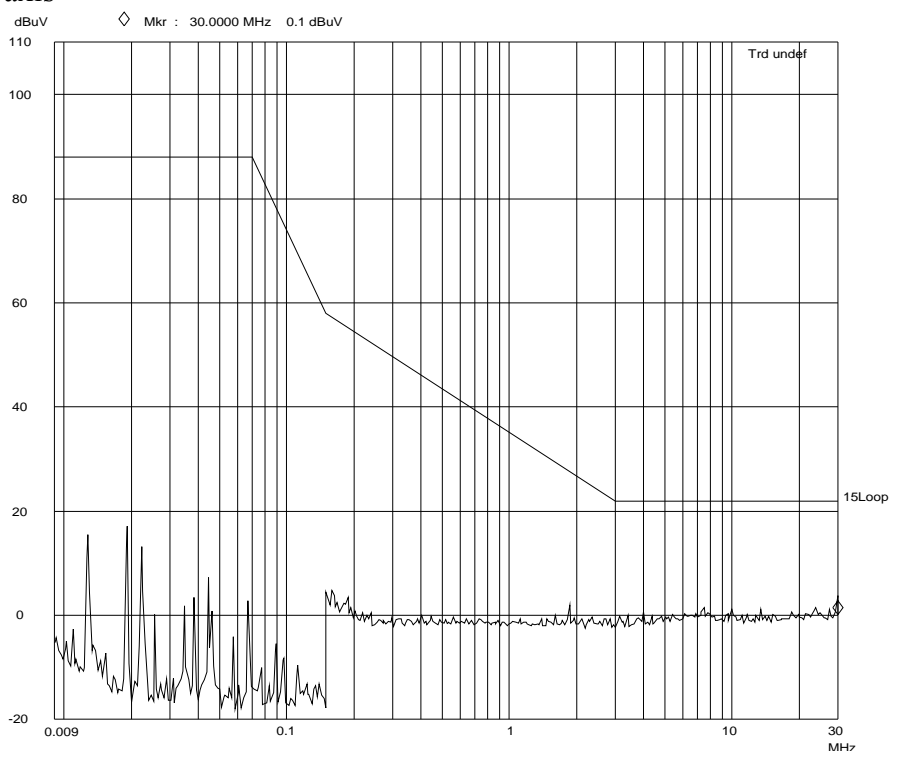

Y axis

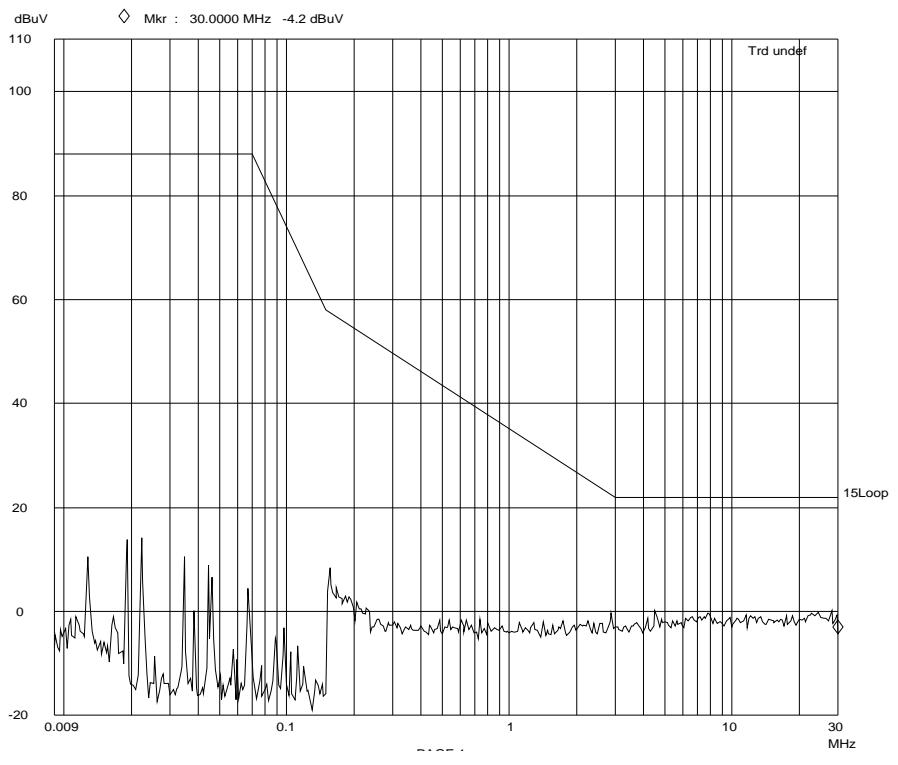

Z axis

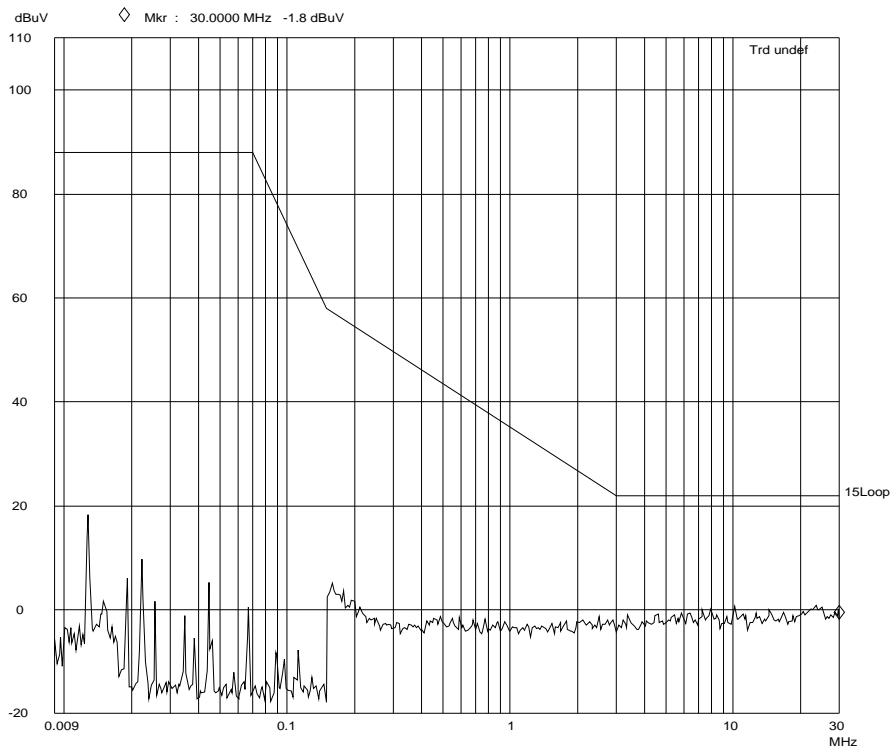

4.2.6 Measurement Uncertainty

The measurement uncertainty for induction current is under consideration according to CISPR 16-4-2:2003.

4.3 EN 55015 Radiated Electromagnetic Disturbance (30 MHz -300 MHz, CDN method)
Test Result: Pass

4.3.1 Used Test Equipment

Equip. No.	Equipment	Model	Manufacturer
EM004-04	EMC shield Room	8m×3m×3m	Zhongyu
EM080-05	EMI receiver	ESCI	R&S
EM003-02	Coupling & Decoupling Network	CDN M2 16	TESEQ
EM003-01-05	Attenuator	6dB	drhubert

4.3.2 Block Diagram of Test Setup

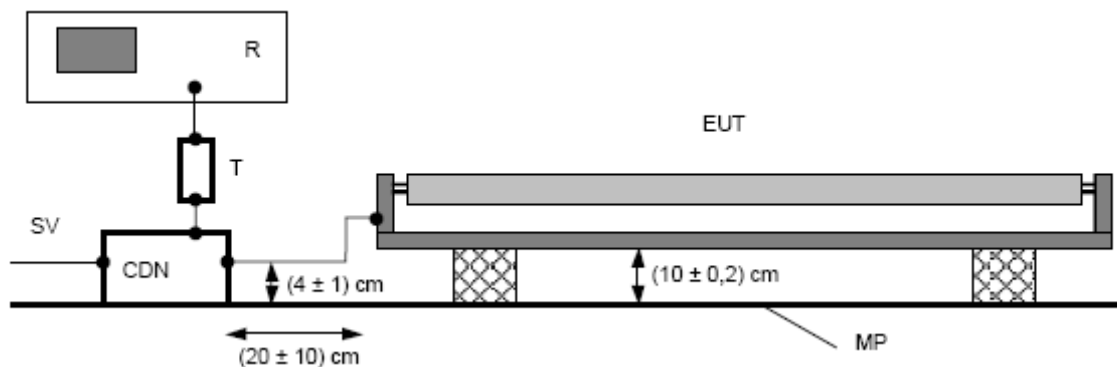

4.3.3 Test Setup and Procedure

The EUT shall be placed on a non-conducting table with a height of (10 ± 0.2) cm.
 The EUT is connected to CDN with a length of (20 ± 10) cm and the distance of the cable to the metal plate should be (4 ± 1) cm.
 The RF output of the CDN is connected to EMI receiver via a 6 dB, 50Ω attenuator.
 The distance from any conductive parts shall be more than 40 cm.

Prior to a measurement, the lamps shall be operated until stabilization has been reached.
 5min for incandescent lamps, 15min for fluorescent lamp, 30min for other discharge lamp.

The EUT should be powered on before the coaxial cable is connected to receiver every time.
 And the coaxial cable should be removed from receiver before stopping EUT.

4.3.4 Test Data

EIP008C0200LS

EDIT PEAK LIST (Final Measurement Results)				
Trace1:	15CDN			
Trace2:	---			
Trace3:	---			
TRACE	FREQUENCY	LEVEL dBμV		DELTA LIMIT dB
1 Quasi Peak	73.52 MHz	45.77	L1	-10.78
1 Quasi Peak	69.84 MHz	46.06	L1	-10.92
1 Quasi Peak	60.64 MHz	44.57	L1	-13.58
1 Quasi Peak	47.92 MHz	43.99	L1	-16.11

EIP008C0600LS

EDIT PEAK LIST (Final Measurement Results)				
Trace1:	15CDN			
Trace2:	---			
Trace3:	---			
TRACE	FREQUENCY	LEVEL dBμV		DELTA LIMIT dB
1 Quasi Peak	71.44 MHz	46.83	L1	-9.95
1 Quasi Peak	67.64 MHz	47.19	L1	-10.04
1 Quasi Peak	54.6 MHz	46.70	L1	-12.32
1 Quasi Peak	53.08 MHz	46.58	L1	-12.68
1 Quasi Peak	82.28 MHz	40.26	L1	-15.35
1 Quasi Peak	42.64 MHz	45.55	L1	-15.52

EIP008C1000LS

EDIT PEAK LIST (Final Measurement Results)				
Trace1:	15CDN			
Trace2:	---			
Trace3:	---			
TRACE	FREQUENCY	LEVEL dBμV		DELTA LIMIT dB
1 Quasi Peak	68.2 MHz	45.72	L1	-11.45
1 Quasi Peak	71.44 MHz	44.85	L1	-11.94
1 Quasi Peak	58.52 MHz	45.52	L1	-12.93
1 Quasi Peak	53.24 MHz	45.78	L1	-13.45
1 Quasi Peak	83.44 MHz	39.56	L1	-15.93
1 Quasi Peak	39.88 MHz	45.04	L1	-16.58
1 Quasi Peak	43.84 MHz	44.14	L1	-16.70

4.3.5 Test Curve EIP008C0200LS

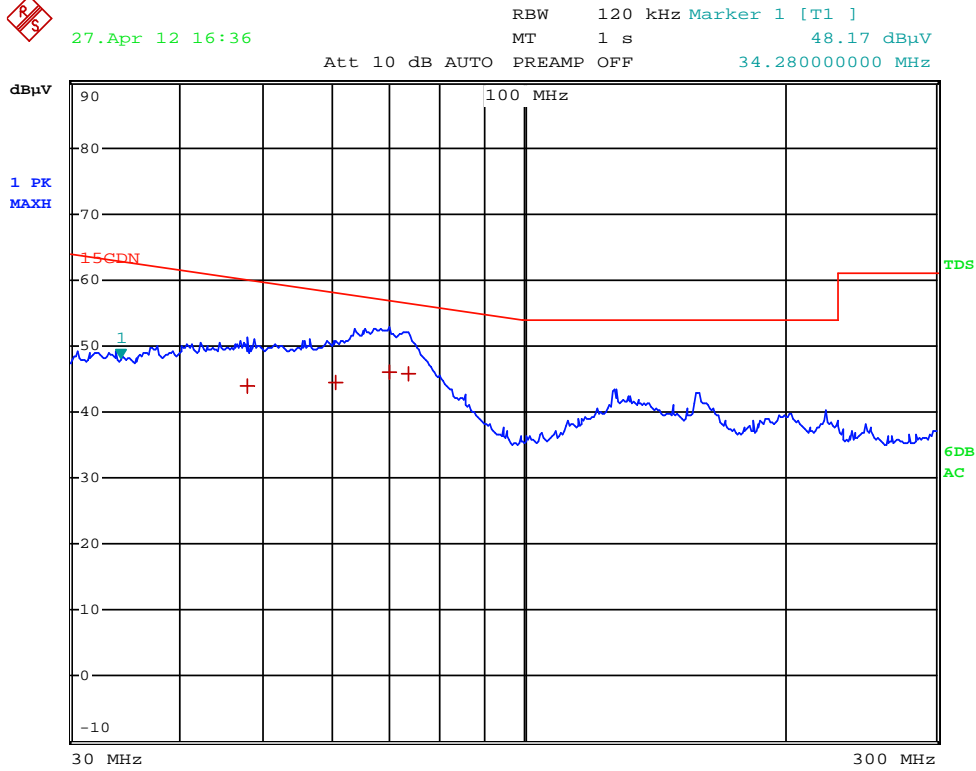

EIP008C0600LS

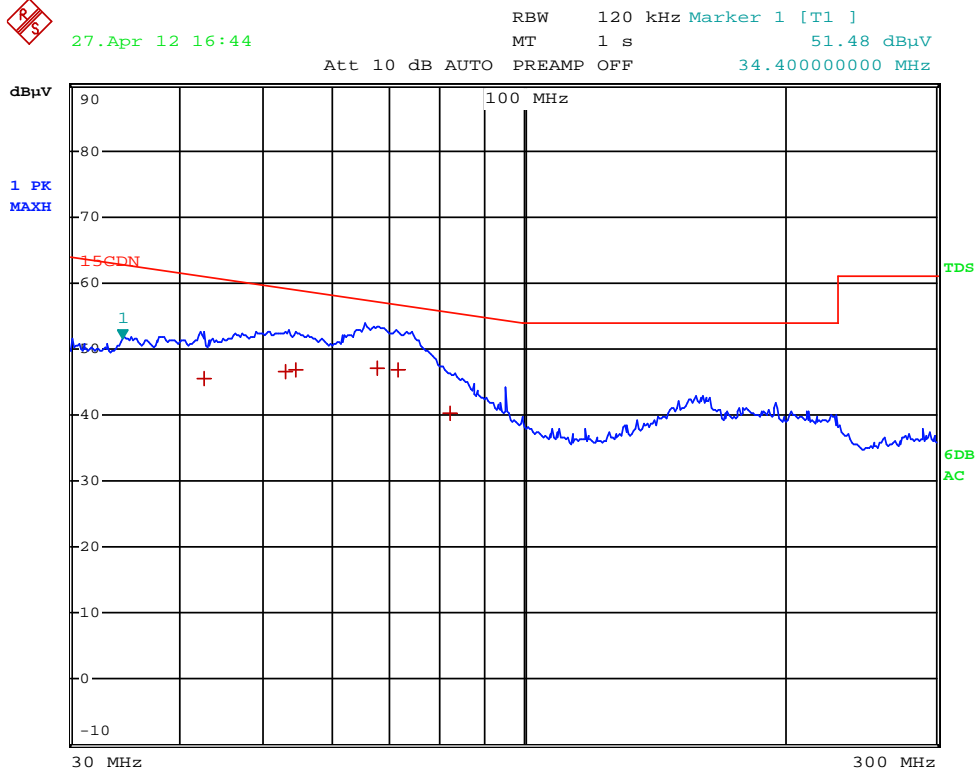

EIP008C1000LS

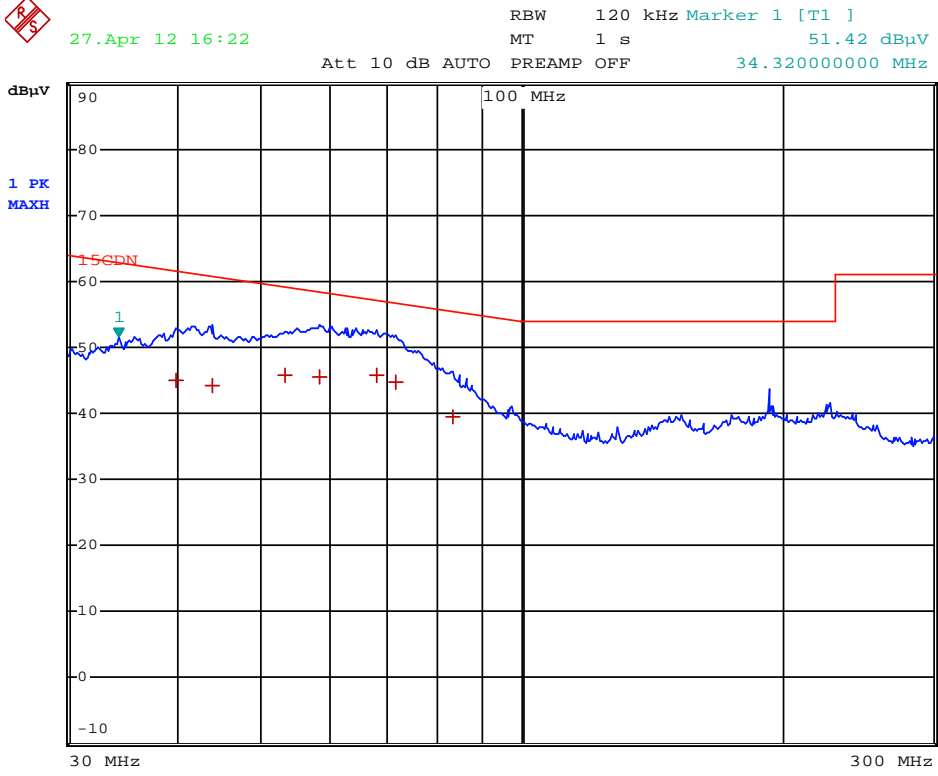

4.3.6 Measurement uncertainty

The measurement uncertainty for Radiated Electromagnetic Disturbance t (30 MHz -300 MHz, CDN method) is under consideration according to CISPR 16-4-2:2003.

4.4 Insertion Loss

Test Result: Not Applicable.
Remark: Not required by standard.

5 Harmonics of current**Test Result: Pass****Remark:**

EUT is not discharge lighting, the harmonics currents limits are not specified for the equipment with a rated power smaller than or equal to 25W. Therefore the EUT was deemed fulfill the requirements of relative standard without testing.

6 Flicker**Test Result: Pass****Remark:**

The EUT are unlikely to produce significant voltage fluctuations or flicker, so no flicker tests are performed.

7 EMS TEST

Performance Criteria:

- Criterion A: During the test no change of the luminous intensity shall be observed and the regulating control, if any, shall operate during the test as intended.
- Criterion B: During the test the luminous intensity may change to any value. After the test the luminous intensity shall be restored to its initial value within 1 min.
Regulating controls need not function during the test, but after the test the mode of the control shall be the same as before the test provided that during the test no mode changing commands were given.
- Criterion C: During and after the test any change of the luminous intensity is allowed and the lamp(s) may be extinguished. After the test, within 30 min, all functions shall return to normal if necessary by temporary interruption of the mains supply and /or operating the regulating control.
Additional requirement for lighting equipment incorporation a starting device:
After the test the lighting equipment is switched off. After half an hour it is witched on again. The lighting equipment shall start and operate as intended.

Measurement Uncertainty

According to CISPR 16-4-2:2003, measurement uncertainty to immunity test is under consideration.

Note: "N/A" means Not Applicable in below text.

7.1 EN 61000-4-2(Pursuant to EN 61547) Electrostatic Discharge Immunity

Performance criterion: B

Test Result: Pass

7.1.1 Used Test Equipment

Equip. No.	Equipment	Model	Manufacturer
EM077-02	ESD Simulator	NSG435	SCHAFFNER

7.1.2 Block Diagram of Test Setup

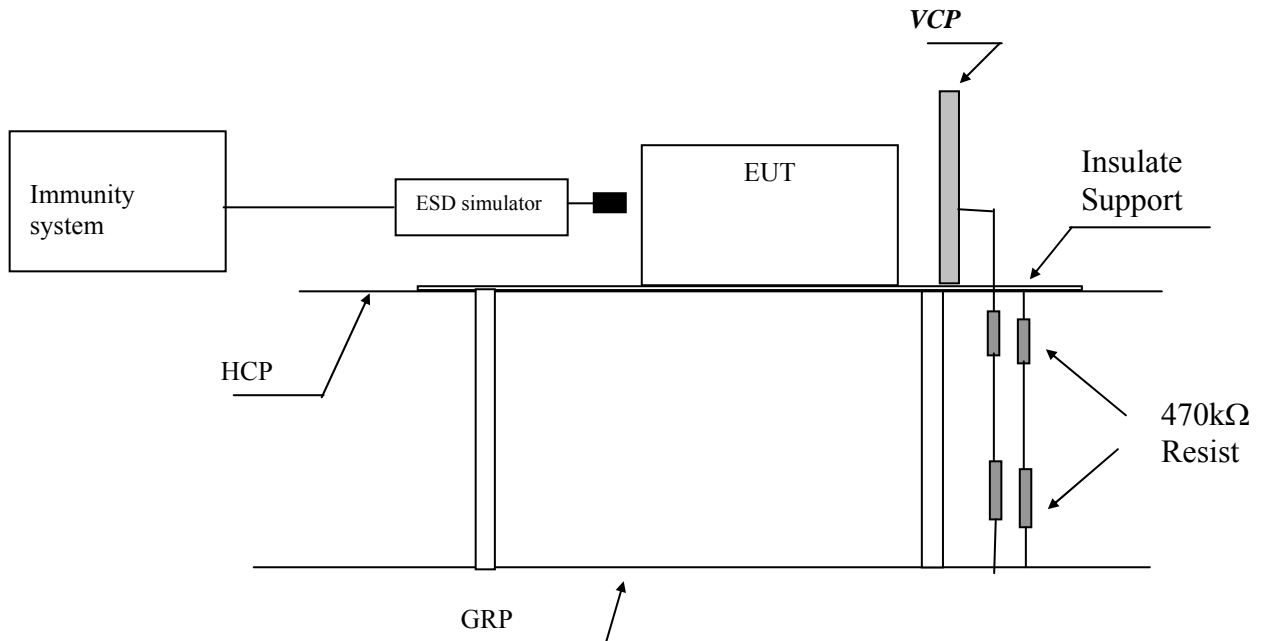

Note: HCP means Horizontal Coupling Plane,
 VCP means Vertical Coupling Plane
 GRP means Ground Reference Plane

7.1.3 Test Setup and Procedure

The EUT was put on a $(0,8 \pm 0,08)$ m high wooden table/0.1m high for floor standing equipment standing on the ground reference plane (GRP) 3m by 2m in size, made by iron 1.0 mm thick. A horizontal coupling plane (HCP) $(1,6 \pm 0,02)$ m by $(0,8 \pm 0,02)$ m in size was placed on the table, and the EUT with its cables were isolated from the HCP by an insulating support with $(0,5 \pm 0,05)$ mm thick. The VCP 0.5m by 0.5m in size & HCP were constructed from the same material type & thickness as that of the GRP, and connected to the GRP via a 470kΩ resistor at each end.

For floor standing equipment, The EUT shall be isolated from the ground reference plane by an insulating support of 0,05 m to 0,15 m thick. The EUT cables shall be isolated from the ground reference plane by an insulating support of $(0,5 \pm 0,05)$ mm. This cable isolation shall extend beyond the edge of the EUT isolation.

The distance between EUT and any of the other metallic surface excepted the GRP, HCP & VCP was greater than 0.8m.

The EUT was arranged and connected according to its functional requirements.

Direct static electricity discharges was applied only to those points and surface which are accessible to personnel during normal usage, terminals are excluded.

On each preselected points 10 times of each polarity single discharge were applied .

The ESD generator was held perpendicular to the surface to which the discharge is applied.

The discharge return cable of the generator was kept at a distance of 0.2m whilst the discharge is being applied. During the contact discharges, the tip of the discharge electrode was touch the EUT before the discharge switch is operated. During the air discharges, the round discharge tip of the discharge electrode was approached as fast as possible to touch the EUT.

Indirect discharge was conducted to objects placed near the EUT, simulated by applying the discharges of the ESD generator to a coupling plane, in the contact discharge mode.

After each discharge, the ESD generator was removed from the EUT, the generator is then retriggered for a new single discharge. For ungrounded product, a grounded carbon fibre brush with bleeder resistors ($2 \times 470 \text{ k}\Omega$) in the grounding cable was used after each discharge to remove remnant electrostatic voltage.

10 times of each polarity single discharge were applied to HCP and VCP. The detail selected points are listed in the following table.

7.1.4 Test Result

Direct Application of ESD

Direct Contact Discharge

Applied Voltage (kV)	No. of Discharge for each point	Result (Pursuant to EN 61547)	Discharged Points
4	20	Pass	Accessible metal parts of the EUT.

Direct Air Discharge

Applied Voltage (kV)	No. of Discharge for each point	Result (Pursuant to EN 61547)	Discharged Points
2, 4, 8	20	Pass	All accessible points where contact discharge cannot be applied such as Air gap.

Indirect Application of ESD

Horizontal Coupling Plane under the EUT

Applied Voltage (kV)	No. of Discharge for each point	Result (pursuant to EN 61547)	Discharged Point
4	20	Pass	At the front edge of each HCP opposite the centre point of each unit of the EUT

Vertical Coupling Plane beside the EUT

Applied Voltage (kV)	No. of Discharge for each point	Result (pursuant to EN 61547 criterion B)	Discharged Point
4	20	Pass	The centre of the vertical edge of the coupling plane

7.2 EN 61000-4-6(Pursuant to EN 61547) Injected Current (0.15 MHz to 80 MHz)

Performance criterion: A

Test Result: Pass

7.2.1 Used Test Equipment

Equip. No.	Equipment	Model	Manufacturer
EM019-01	Conducted Immunity Testing System	NSG4070-75	Teseq GmbH
EM019-01-02	Coupling & Decoupling Network	CDNM016	Teseq GmbH
EM019-01-03	6dB Attenuator	ATN6075	Teseq GmbH

7.2.2 Block Diagram of Test Setup

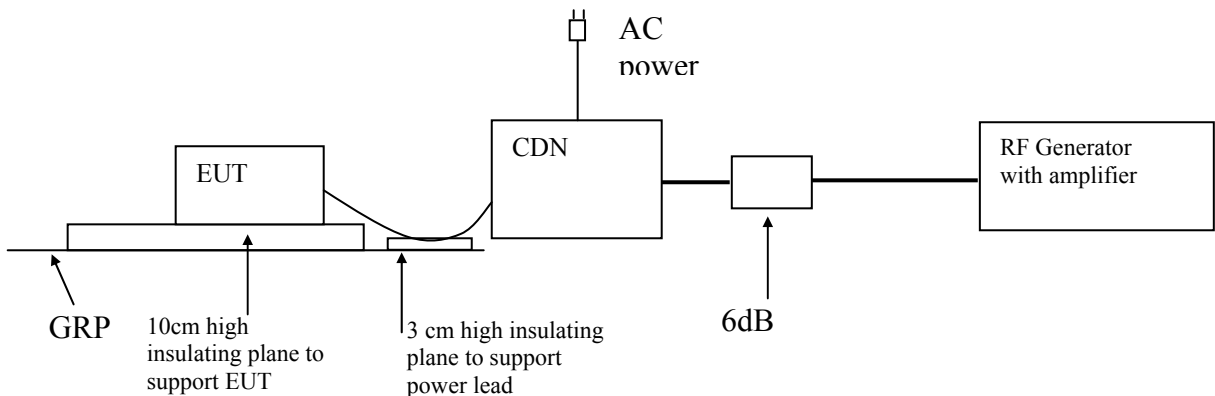

7.2.3 Test Setup and Procedure

The EUT was placed on an insulating support of 0.1m height above a ground reference Plane, arranged and connected to satisfy its functional requirement.

All relevant cables were provided with the appropriate coupling and decoupling devices at a distance between 0.1m and 0.3m from the projected geometry of the EUT on an insulating support of 0.03m height above the ground reference plane.

Test voltage was verified before each testing though power meter combined in the RF generator with AMP.

Dwell time was set to 3s and step was set as 1% to keep sufficient response time for EUT.

The frequency from 0.15MHz to 80MHz was checked.

7.2.4 Test Result

Port:	Frequency (MHz)	Level (Pursuant to EN 61547)	Result
A.C. Power Lines	0.15 to 80	3V (r.m.s.)	Pass
D.C. Power Lines	0.15 to 80	3V (r.m.s.)	N/A
Signal Lines	0.15 to 80	3V (r.m.s.)	N/A
Control Lines	0.15 to 80	3V (r.m.s.)	N/A

7.3 EN 61000-4-4(Pursuant to EN 61547) Electrical Fast Transient/Burst

Performance criterion: B

Test Result: Pass

7.3.1 Used Test Equipment

Equipment No.	Equipment	Model	Manufacturer
EM005-07	EMS test system	Ecompact 4	HAEFELY

7.3.2 Block Diagram of Test Setup

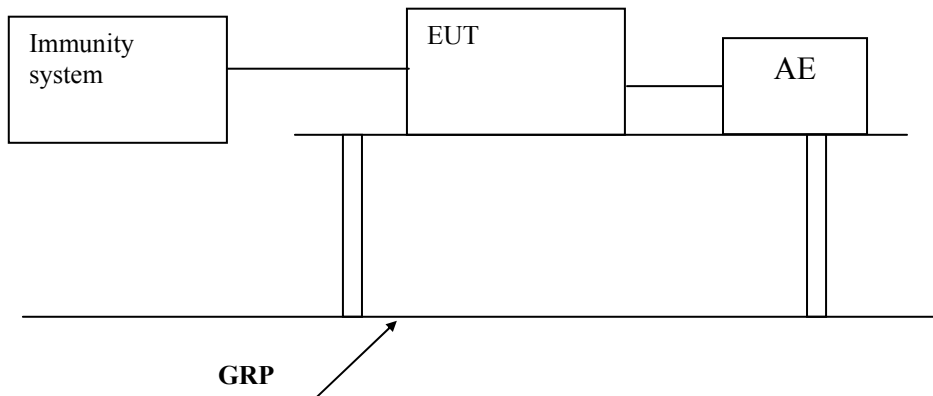

7.3.3 Test Setup and Procedure

The EUT was placed on a 0.1m high wooden table, standing on the ground reference plane 3m by 2m in size, made by steel 1mm thick.

The distance between the EUT and any other of the metallic surface except the GRP is greater than 0.5m.

The mains lead excess than 0.5m is folded to avoid a flat coil and situated at a distance of 0.1m above the ground reference plane to insure the distance between the coupling device and the EUT were 0.5m.

The EUT was arranged and connected to satisfy its functional requirement and supplied by the coupling-decoupling network.

7.3.4 Test Result

Level (Pursuant to EN 61547)	Polarity	Input and Output A.C. Power Ports	D.C. Power Ports, Signal and Control Lines
0.5kV	+	N/A	N/A
0.5kV	-	N/A	N/A
1kV	+	Pass	N/A
1kV	-	Pass	N/A

7.4 EN 61000-4-5(Pursuant to EN 61547) Surge Immunity

Performance criterion: C

B (luminaire for emergency lighting)

Test Result: Pass

7.4.1 Used Test Equipment

Equipment No.	Equipment	Model	Manufacturer
EM005-09	Surge/DIP Generator	NSG3040	TESEQ

7.4.2 Block Diagram of Test Setup

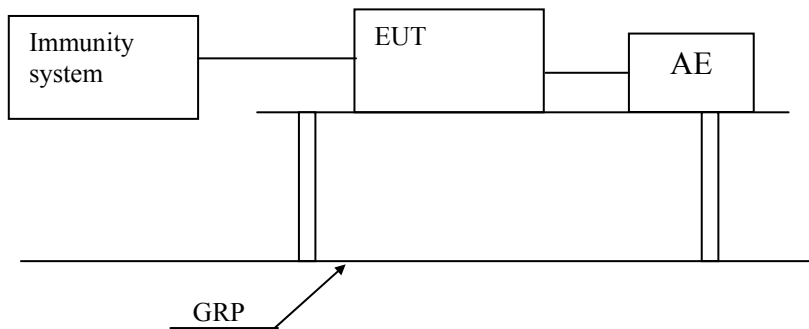

7.4.3 Test Setup and Procedure

The surge is to be applied to the EUT power supply terminals via the capacitive coupling network.

Decoupling networks are required in order to avoid possible adverse effects on equipment not under test that may be powered by the same lines and to provide sufficient decoupling impedance to the surge wave so that the specified wave may be developed on the lines under test.

The EUT was arranged and connected according to its functional requirements.

The EUT was placed on a 0.1m high wooden support above the GRP), supplied by the coupling-decoupling network, and arranged and connected to satisfy its functional requirement. The power cord between the EUT and the coupling/decoupling network was less than 2 meters.

Five positive and five negative pulses shall be applied at the peak value and zero crossing points of the a.c. voltage wave.

7.4.4 Test Result

I. For Self-ballasted lamps and semi-luminaires and independent auxiliaries with input power less or equal to 25 W:

Level (Pursuant to EN 61547)	Result
Between Phase And Phase: 0.5 kV	N/A
Between Phase And Neutral: 0.5 kV	Pass
Between Phase And Earth: 0.5 kV, 1.0 kV	N/A
Between Neutral And Earth: 0.5 kV, 1.0 kV	N/A

II. For luminaires and independent auxiliaries with input power greater than 25 W:

Level (Pursuant to EN 61547)	Result
Between Phase And Phase: 0.5 kV, 1.0 kV	N/A
Between Phase And Neutral: 0.5 kV, 1.0 kV	N/A
Between Phase And Earth: 0.5 kV, 1.0 kV, 2.0 kV	N/A
Between Neutral And Earth: 0.5 kV, 1.0 kV, 2.0 kV	N/A

7.5 EN 61000-4-11(Pursuant to EN 61547) Voltage Dips and Interruptions

Performance criterion:

for table 11 of EN 61547 ----- **C**

for table 12 of EN 61547----- **B**

Test Result: Pass

7.5.1 Used Test Equipment

Equipment No.	Equipment	Model	Manufacturer
EM005-07	EMS test system	Ecompact 4	HAEFELY

7.5.2 Block Diagram of Test Setup

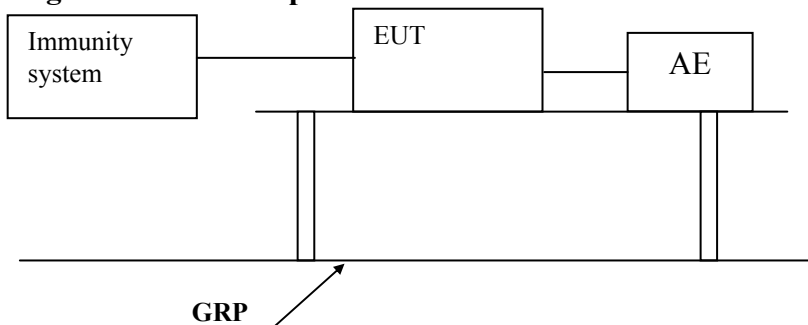

7.5.3 Test Setup and Procedure

The EUT was placed on an insulating support of 0.8m height, standing on a ground reference plane, and arranged and connected to satisfy its functional requirement

The test was performed with the EUT connected to the test generator with the shortest power supply cable as specified by the EUT manufacturer.

The EUT was tested for each selected combination of test level and duration with a sequence of three dips/interruptions with intervals of 10 s minimum. Each representative mode of operation was tested.

EUT is tested for voltage reduction of 0% U_T , 0.5 period, 70% U_T , 10 periods, both the positive and negative polarity test was conducted.

Changes to the voltage level shall occur at a zero crossing point in the a.c. voltage waveform.

7.5.4 Test Result

I. According to table 11 of EN 61547

Test condition (Pursuant to EN 61547)		Result
Test Level in % U_T	Duration (in period of the rated frequency)	
70	10	Pass

II. According to table 12 of EN 61547

Test condition (Pursuant to EN 61547)		Result
Test Level in % U_T	Duration (in period of the rated frequency)	
0	0.5	Pass

Remark: U_T is the rated voltage for the equipment.

7.6 EN 61000-4-3(Pursuant to EN 61547) Radiated Electromagnetic Field Immunity

Performance criterion: A

Test Result: Pass

7.6.1 Used Test Equipment

Equipment No.	Equipment	Model	Manufacturer
103002	Signal generator	SML03	Rohde & Schwarz
10543	Power Meter	4232A	BOOTON
0611-768	Power Amplifier	AP32DT214	PRAnA
0611-767	Power Amplifier	AP32SV150A	PRAnA
75971	Double Log.-Per. Antenna	STLP9128E	SCHWARZBECK
BBHA9120E318/ 0899	Horn Antenna	BBHA 9120 E	SCHWARZBECK

7.6.2 Block Diagram of Test Setup

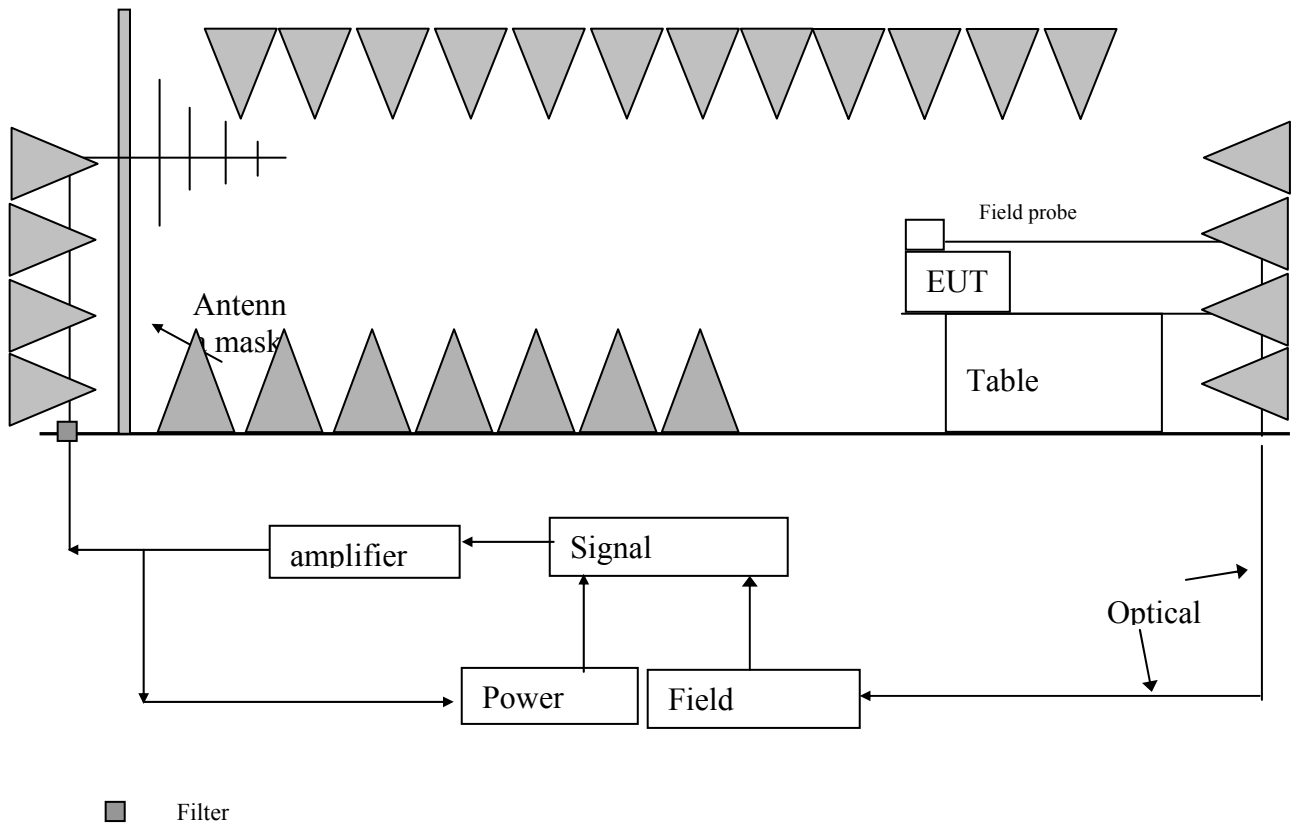

7.6.3 Test Setup and Procedure

The test was conducted in an fully anechoic chamber to maintain a uniform field of sufficient dimensions with respect to the EUT, and also in order to comply with various national and international laws prohibiting interference to radio communications.

The equipment is placed in the test facility on a non-conducting table 0.8m high (for floor standing EUT, is placed on a non-conducting support 0.1m height).

The EUT was placed on the uniform calibrated plane which is 3V/m EM field.

For all ports connected to EUT, manufacturer specified cable type and length was used, for those cables no specification, unshielded cable applied.

Wire is left exposed to the electromagnetic field for a distance of 1m from the EUT.

The EUT was arranged and connected according to its functional requirements

Before testing, the intensity of the established field strength have been checked by placing the field sensor at a calibration grid point, and with the field generating antenna and cables in the same positions as used for the calibration, the forward power needed to give the calibrated field strength was measured.

Spot checks was made at a number of calibration grid points over the frequency range 80MHz to 1000MHz, both polarizations was checked.

After calibration, the EUT is initially placed with one face coincident with the calibration plane.

The frequency range is swept from 80MHz to 1000MHz, with the signal 80% amplitude modulated with a 1 kHz sinewave, pausing to adjust the r.f. signal level.

The dwell time at each frequency was 3s so as that the EUT to be exercised and be able to respond.

The step size was 1% of the fundamental with linear interpolation between calibrated points. Test was performed with the generating antenna facing each of the four sides of the EUT.

7.6.4 Test Result

Frequency (MHz)	Exposed Side	Field Strength (V/m)	Result
80 to 1000	Front	3V/m (r.m.s.)	Pass
80 to 1000	Left	3V/m (r.m.s.)	Pass
80 to 1000	Rear	3V/m (r.m.s.)	Pass
80 to 1000	Right	3V/m (r.m.s.)	Pass

7.7 EN 61000-4-8(Pursuant to EN 61547) Power Frequency Magnetic Field Immunity

Performance criterion: A

Test Result: Not Applicable

Remark:

Equipment containing no Hall elements or magnetic field sensors is not susceptible to magnetic field. Hence, this equipment is deemed to fulfil the magnetic field test.

8 Appendix I - Photos of test setup

Conducted Emission



Radiated Electromagnetic Filed Disturbance



Conducted RF Emission



ESD Immunity

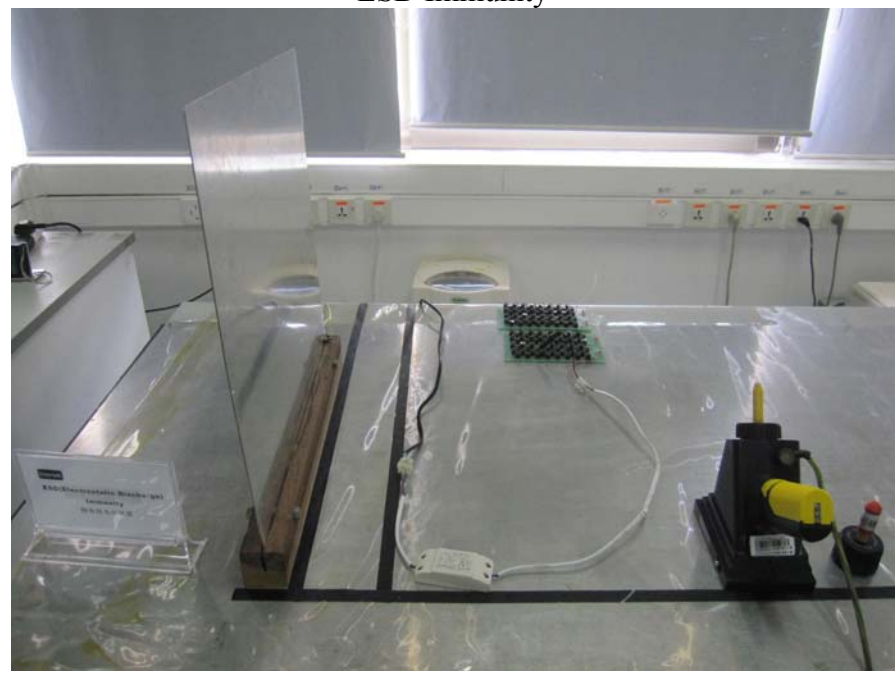

Conducted Immunity

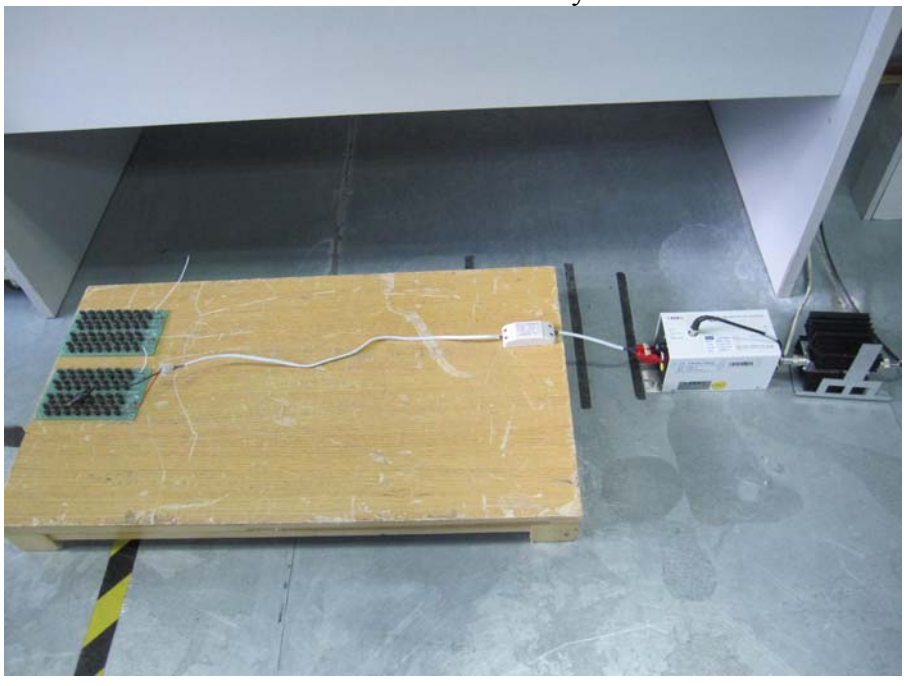

EFT& DIP Immunity



Surge Immunity

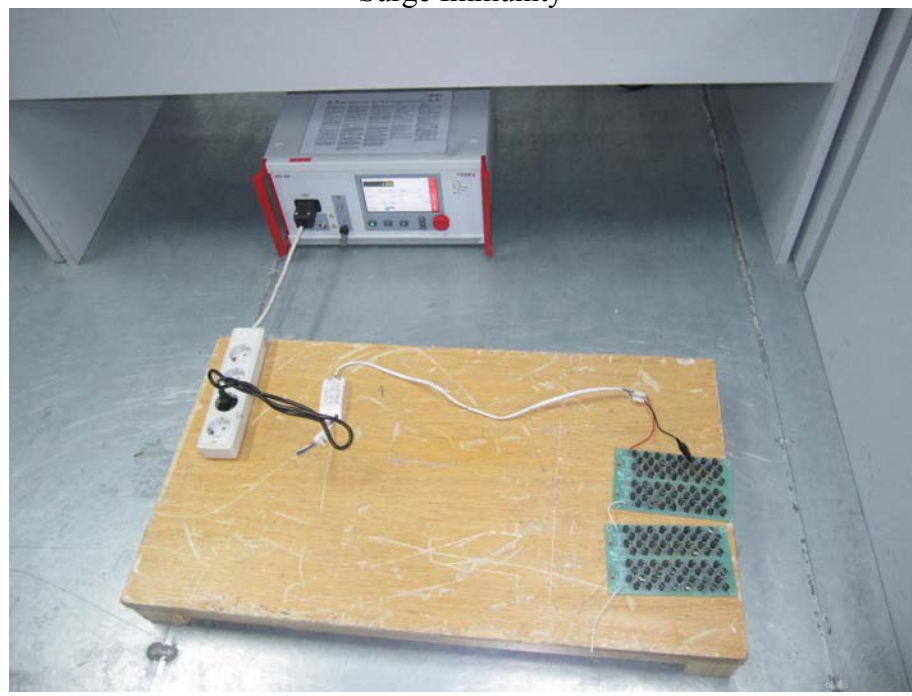

Radiated field Immunity

